

1 Site
1 : 100

AREA SUMMARY		
FLOOR LEVEL	TOTAL AREA (sqm)	REMARKS
LOT AREA = 625 SQM.		
GROUND FLOOR	350.92 m ²	56.14 %
COURTYARD	53.82 m ²	
FIRST FLOOR	328.30 m ²	
ROOF ANNEX	143.38 m ²	40.93 %



1 GROUND FLOOR PLAN
1 : 100

AREA SUMMARY		
FLOOR LEVEL	TOTAL AREA (sqm)	REMARKS
GROUND FLOOR	350.92 m ²	56.14 %
COURTYARD	53.82 m ²	
FIRST FLOOR	328.30 m ²	
ROOF ANNEX	143.38 m ²	40.93 %
LOT AREA = 625 SQM.		

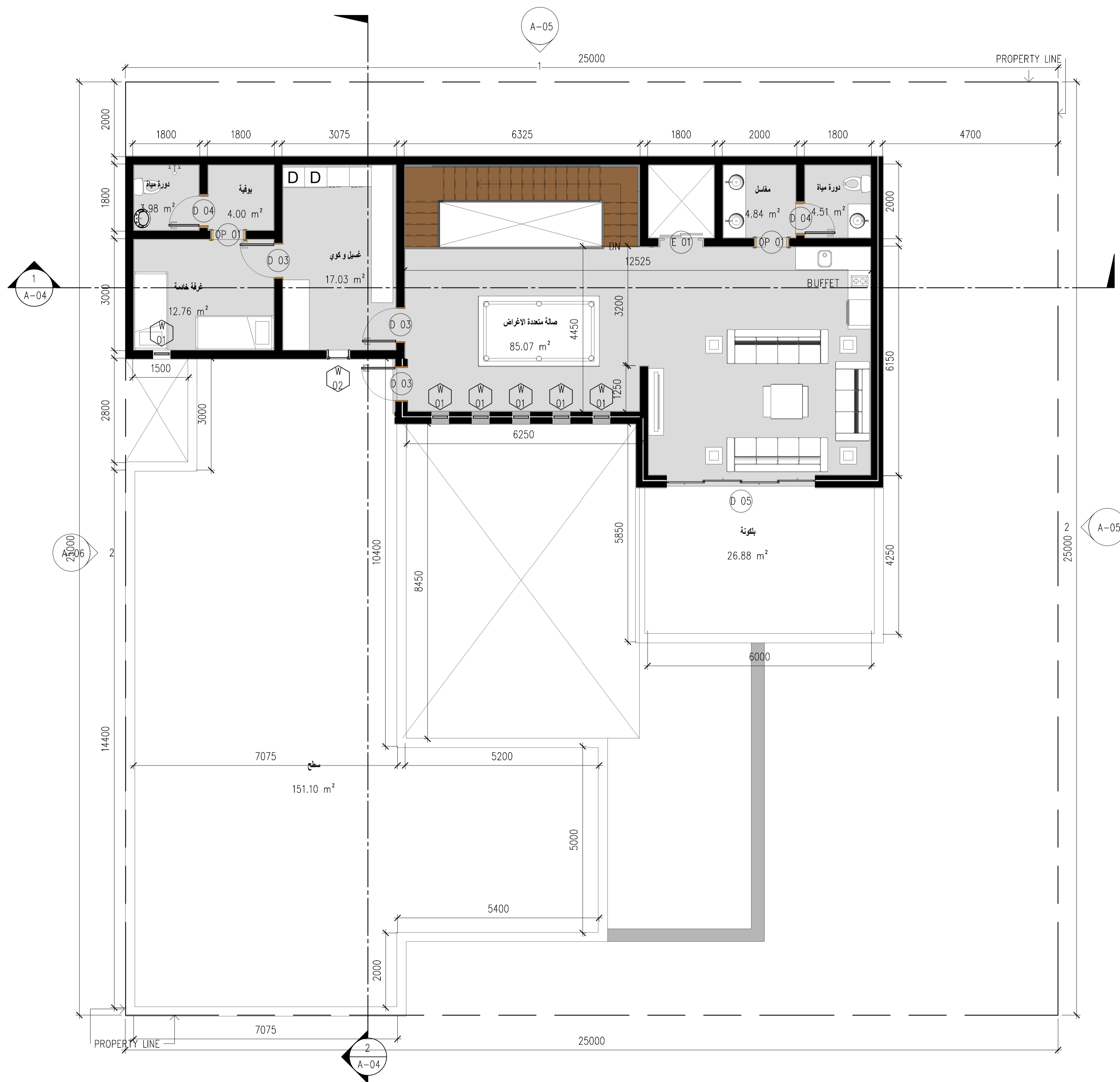
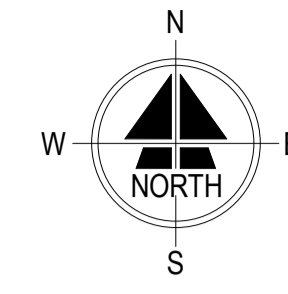

1 ROOF ANNEX FLOOR PLAN
1 : 100

1
A-06

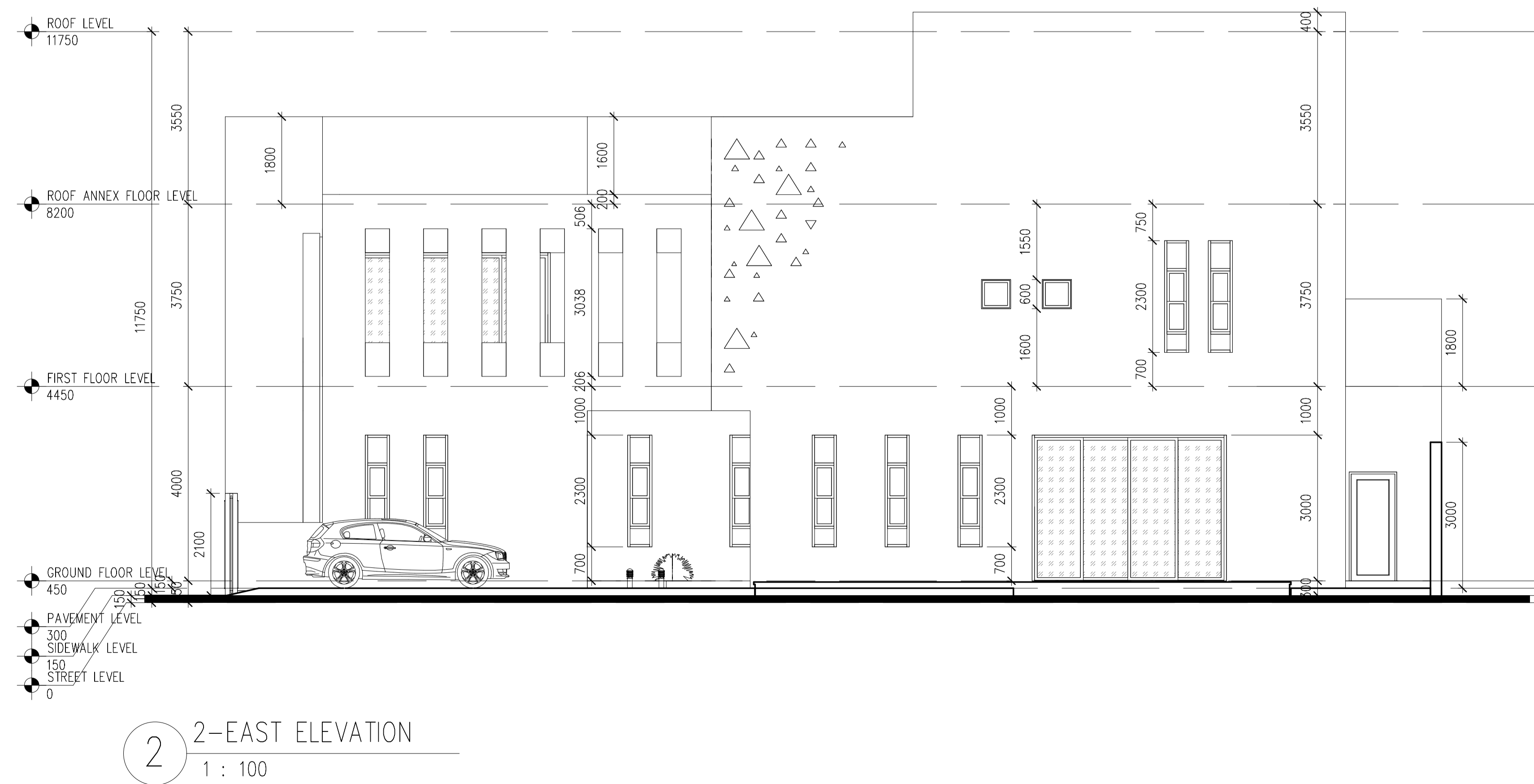
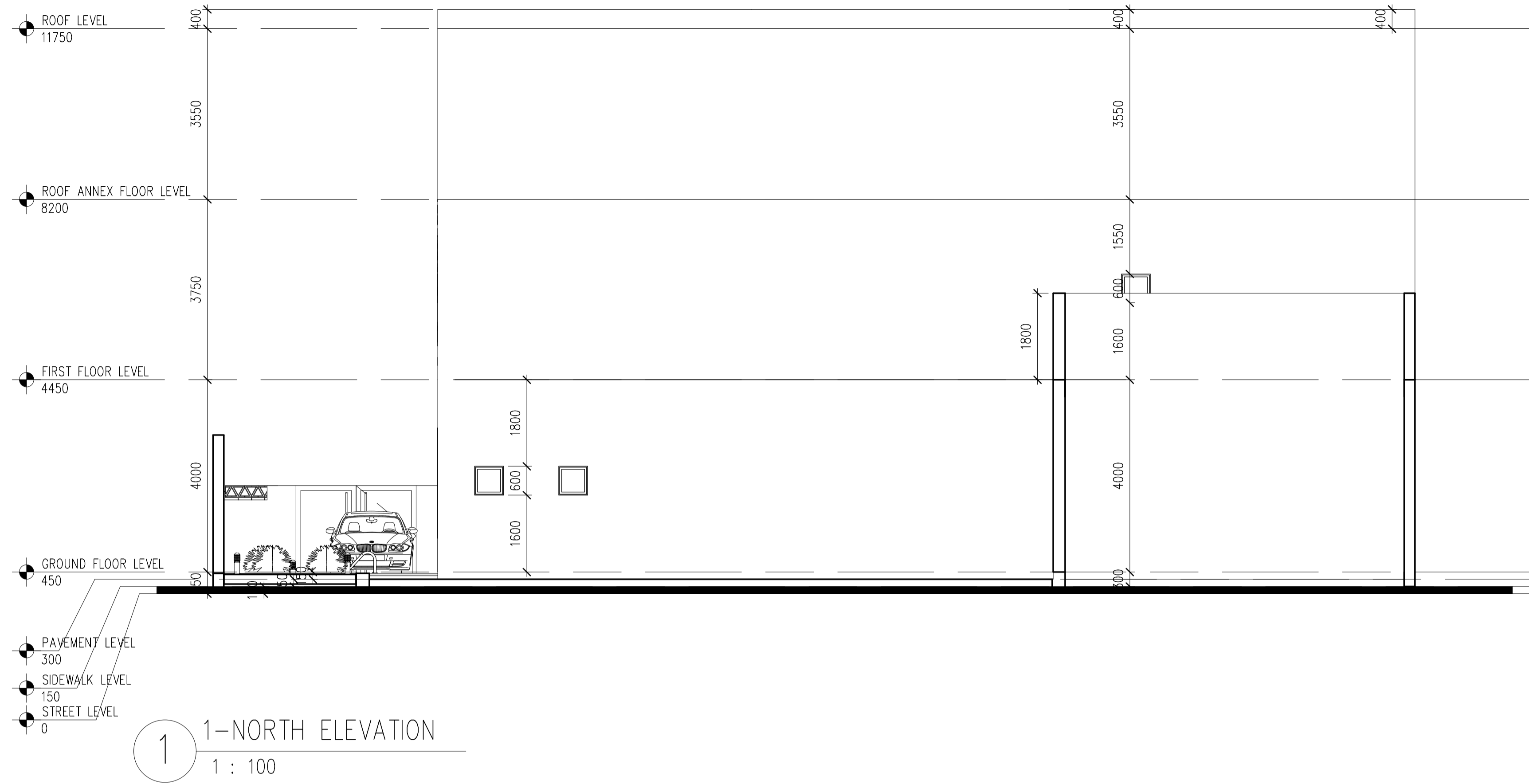

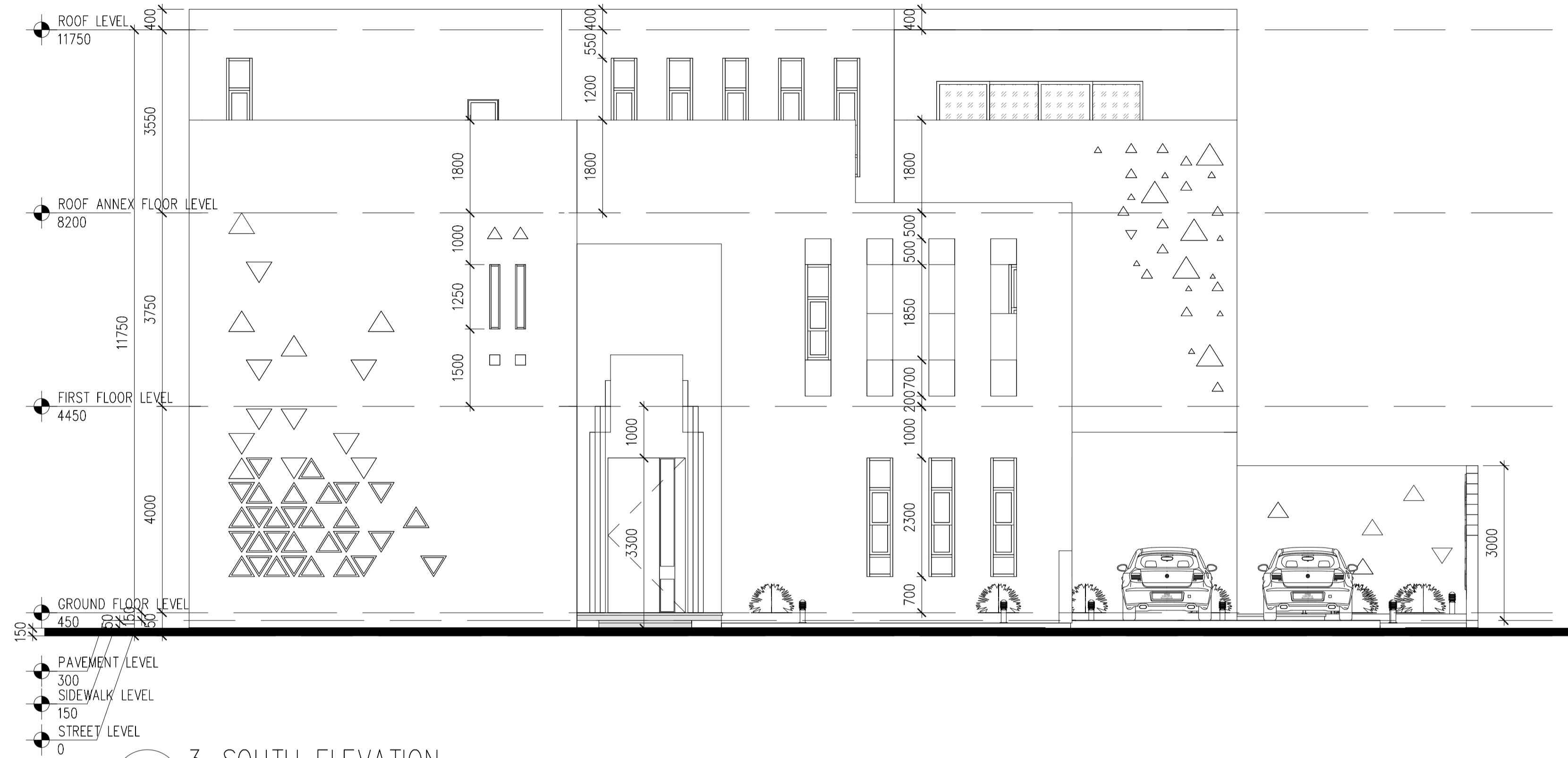

1 3-SOUTH ELEVATION
1 : 100

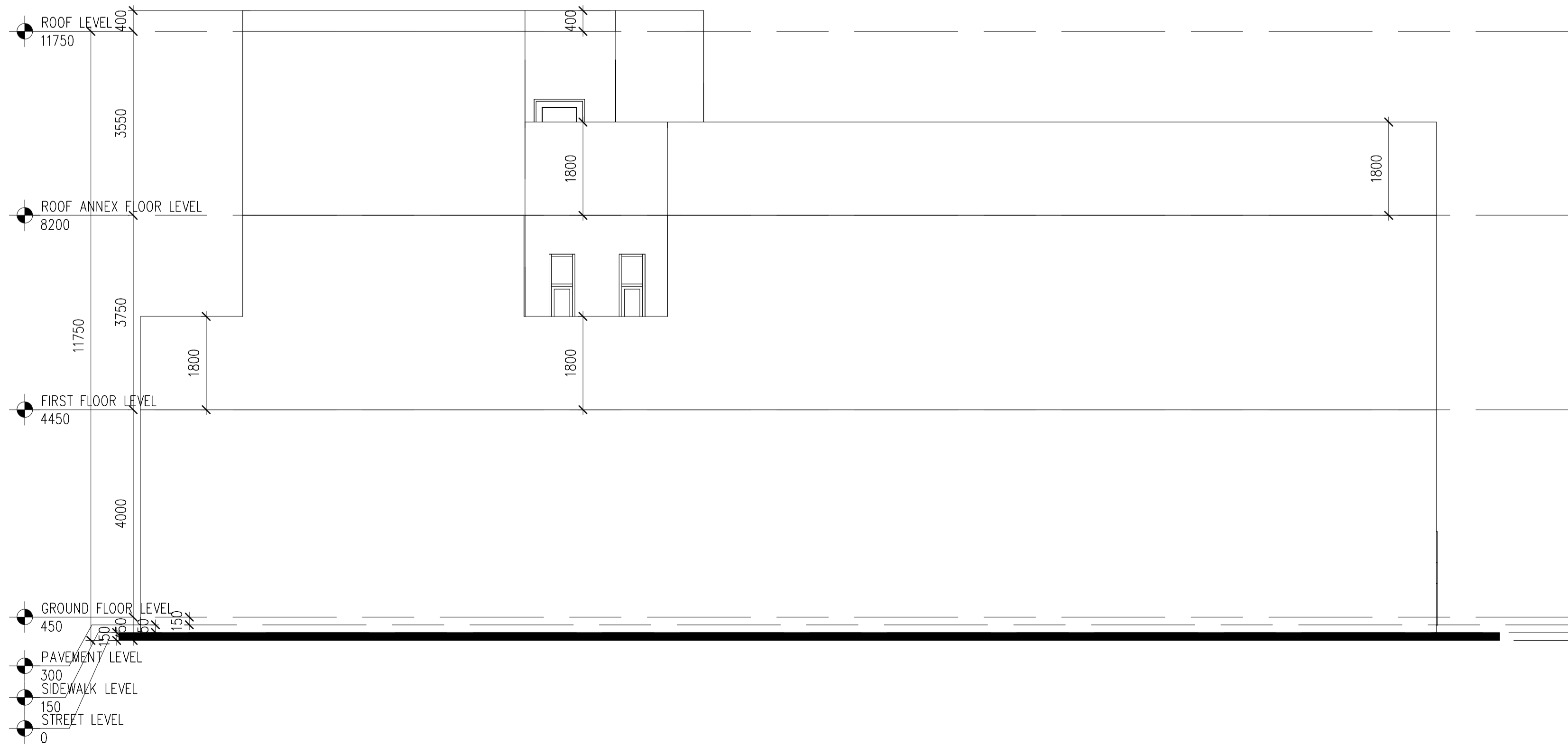

2 4-WEST ELEVATION
1 : 100

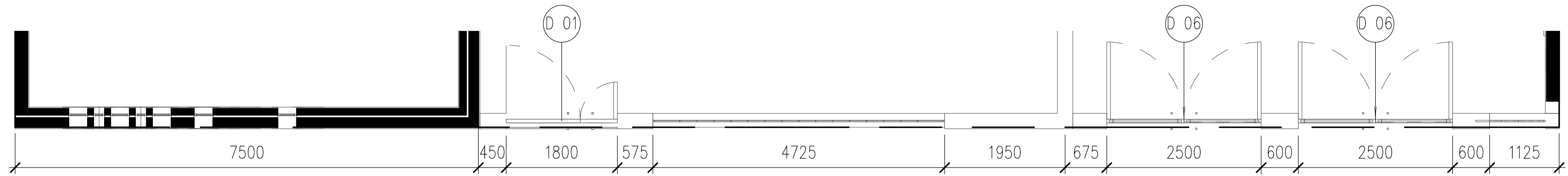

1 FENCE PLAN
1 : 100

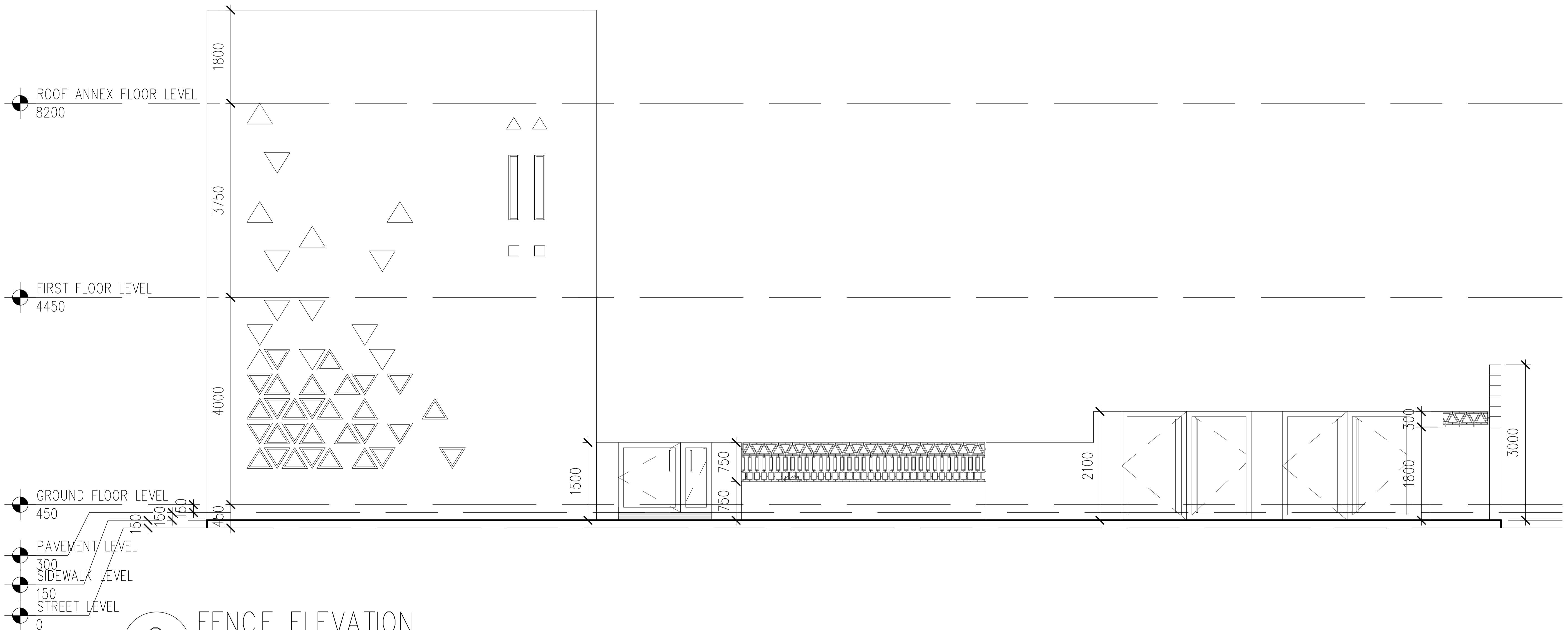

2 FENCE ELEVATION
1 : 100

Door Schedule

Type Mark	Height	Width	Count
D 01	1350	1800	1
D 02	3000	1500	1
D 03	2200	900	10
D 04	2200	800	9
D 05	3000	5000	4
D 06	2100	2500	2
D 07	2000	800	4
E 01	2290	900	3
OP 01	2200	800	11
OP 02	2200	1500	2
OP 03	2200	2200	1

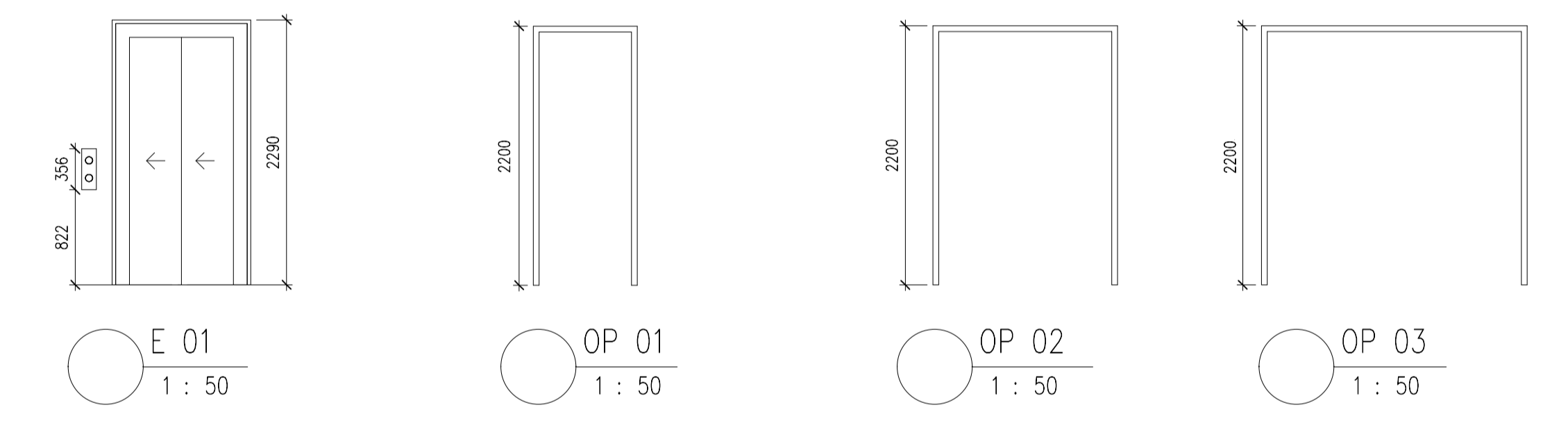
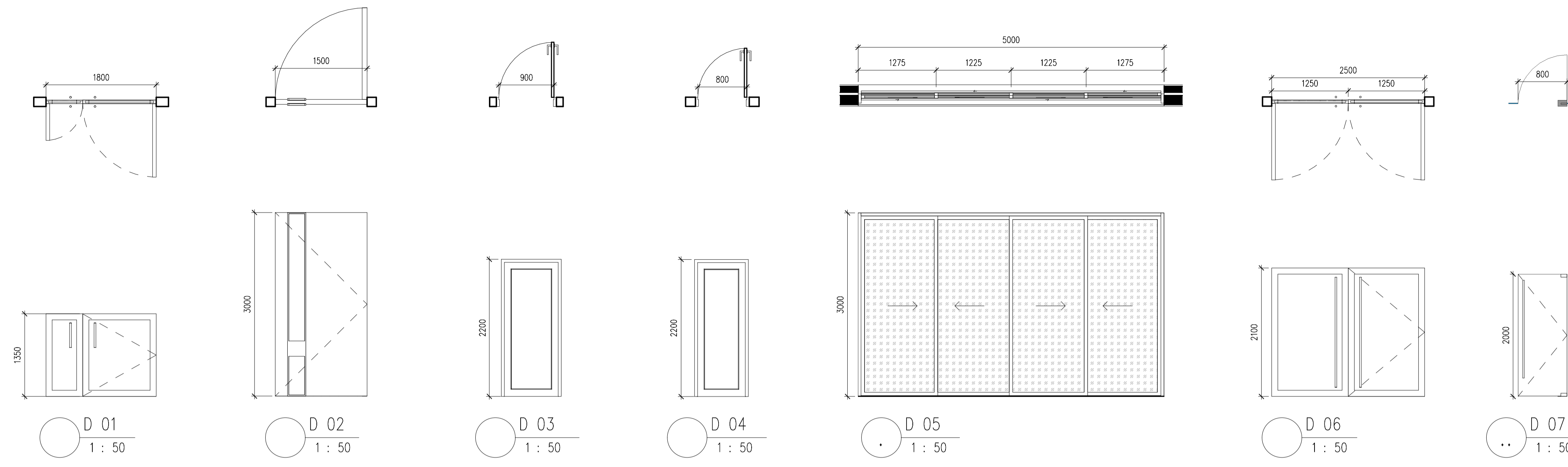

Window Schedule

Type Mark	Height	Width	Count
W 01	2300	500	46
W 02	600	600	6

